



Technical Service BULLETIN

August 22, 2005

Title:

INITIAL CALIBRATION OF COMPASS DURING PDS

Models:

'06 Tacoma

PRE-DELIVERY SERVICE
P D060-05

Introduction The compass indicates the direction that the vehicle is heading by detecting the direction and strength of the Earth's magnetic field and then processes this data using the compass sensor and microcomputer.

Detection of the direction and strength of the Earth's magnetic field varies according to the area in which the vehicle is used and can be affected by the residual magnetism of the vehicle. For this reason, the geographic direction displayed may also deviate from the direction determined by the Earth's magnetic field according to the area in which the vehicle is used.

Perform the initial calibration of the compass in your dealership prior to delivery to customers.

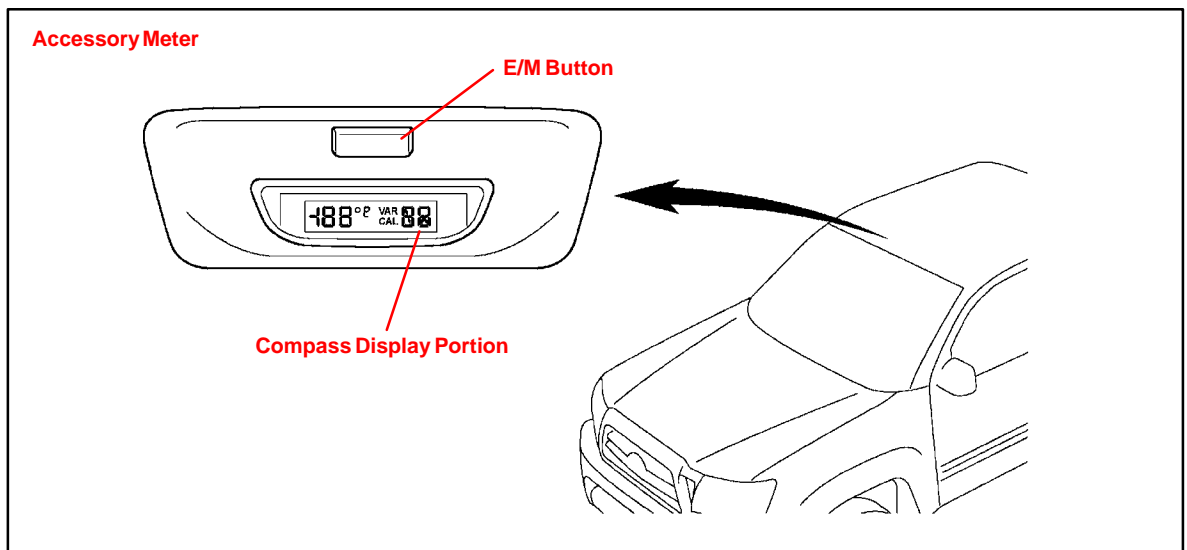

- Applicable Vehicles**
- **2006** model year **Tacoma** vehicles.

Warranty Information

OP CODE	DESCRIPTION	TIME	OFF	T1	T2
N/A	Not Applicable to Warranty	-	-	-	-



Initial Calibration Procedure

1. Turn the ignition switch to the “ON” position and push and hold the “E/M” button until the “VAR” indication appears on the compass display.

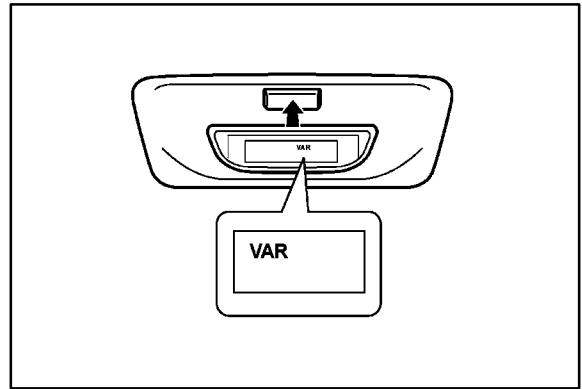

2. Push the “E/M” button within 10 seconds of step 1 to select the number of the zone where the vehicle is located. See the map below for zone reference.

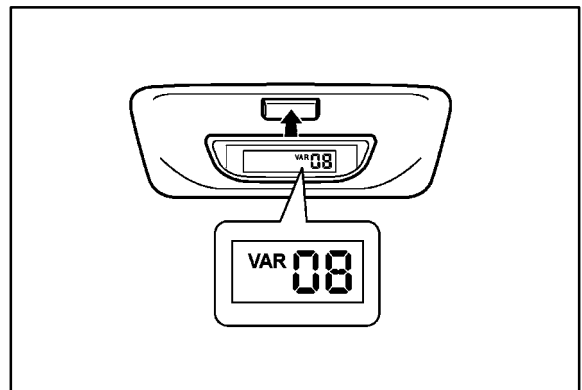

3. After calibration, leave the system alone for 10 seconds to return to the compass mode.

4. Turn ignition switch “OFF.”

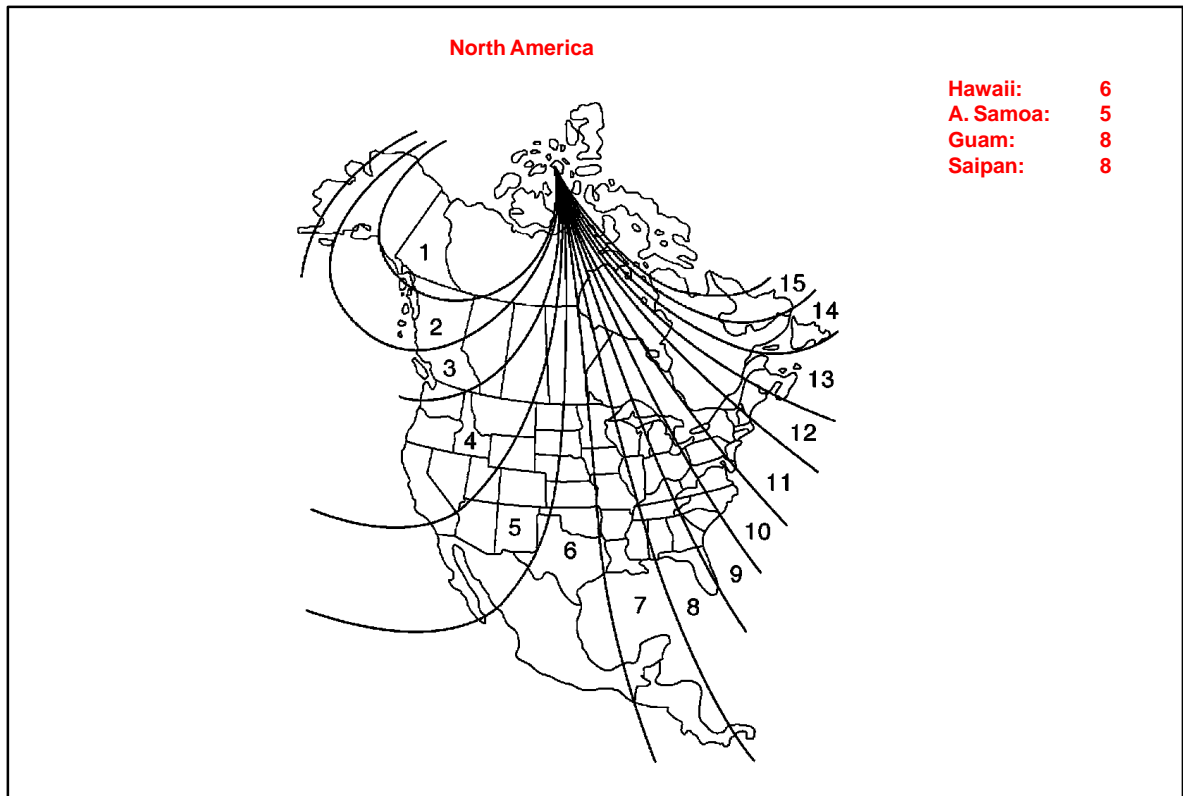

**Initial
Calibration
Procedure**
(Continued)

5. Start the engine and then push and hold the “E/M” button for about 15 seconds until the “CAL” indication appears on the compass display. (At this time, the compass display is locked in “N.”)

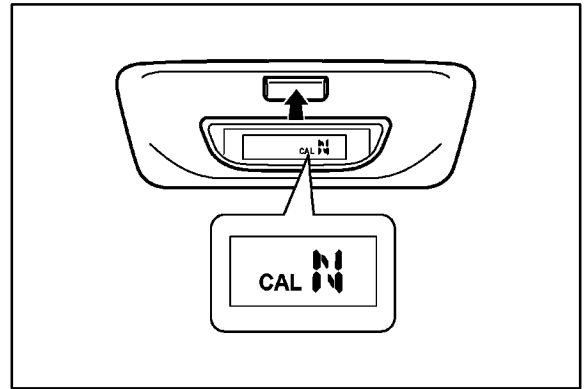

6. Drive the vehicle in a circle at 5 mph (8 km/h) or less. If there is not enough space to drive in a circle, turn the car around as shown, doing two three-point turns in succession.
7. When the “CAL” indication goes off and the compass returns to the normal mode, calibration is completed.

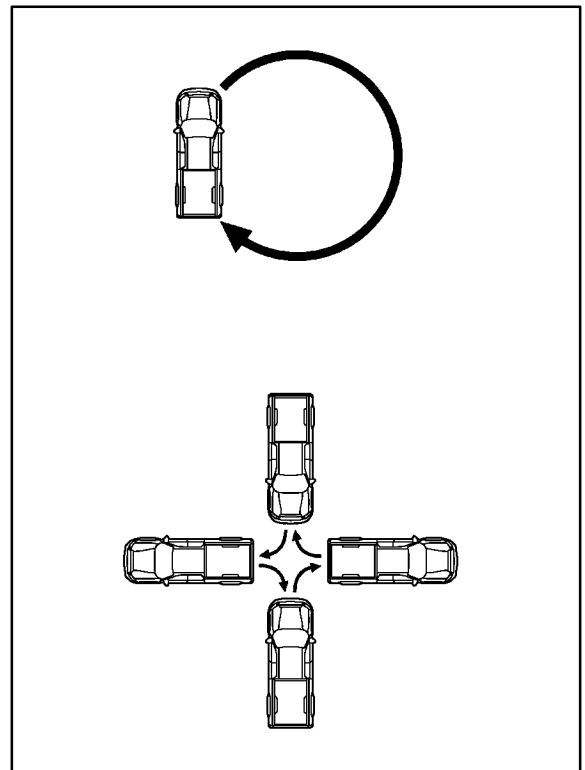

NOTE:

- Do NOT perform calibration of the compass in a place where the Earth's magnetic field is subject to interference by artificial magnetic fields (underground parking, under a steel tower, between buildings, roof parking, near a crossing, near a large vehicle, etc.)
- During calibration, do NOT operate electric systems (moon roof, power windows, etc.) as they may interfere with the calibration.